

Introduction

Controlling the level of an audio signal by means of an applied voltage or current has always been somewhat problematical but often desirable, particularly when it is necessary to control a circuit from a computer. This application note deals with voltage or current controlled attenuators using optocouplers, primarily in relatively static situations (as opposed to the *dynamic* control that occurs in compressors, limiters and noise gates where the gain is continuously being changed in relation to the signal. Although the circuit configurations are broadly similar to those used when switching audio signals, the demands on the optocoupler are rather different, since it is being used as a variable resistance rather than being hard **ON** or **OFF**.

Audiohm optocouplers offer a unique feature set when considering the problem of controlling audio signal levels. The main features are:

1. Very high isolation between control port and audio circuit.
2. Relatively simple drive circuit.
3. Relatively low drive requirement t (<60 mW)
4. Very low control feedthrough.
5. Medium -> good distortion performance.
6. Large signal voltage range: up to 500 V.

To compare their performance with other methods:

Device	Signal voltage	Isolation voltage / feedthrough	Drive complexity	Power consumption#	Distortion	Speed	Cost
Junction FET	a few V	0/medium	high	2...50 mW	medium*	fast	low
Audiohm coupler	60...500 V	>1 KV/v.good	medium	2...100 mW	med...good	Med.	medium
IC VCA	+/-15 V	0/good	low-medium	50...10 0mW	med..good	fast	medium
VCA module	+/-15 V	0/v.good	low	200...50 0mW	good	fast	high
Motor driven potentiometer	50...200 V	>1 KV/good	high	1 W+	v.good	slow	high

#including support circuitry
*depends on drive circuit

Attenuator configurations

Resistive optocouplers can be used in series (**Figure 1**), shunt (**Figure 2**) or series/shunt (**Figure 3**) configurations. The hybrid series shunt (**Figure 4**) is a cross between the shunt and series/shunt and offers some advantages.

In most solid state audio circuits, the optimum source and load resistances are going to fall somewhere in between the R_{ON} and R_{OFF} of the couplers. There is likely to be a significant asymmetry between the "up" (decreasing attenuation) and "down" (increasing attenuation) times of the series and shunt configurations. If this is a problem, it is best to use a coupler with relatively fast response e.g. the **NSL-32SR3**. This device also shows the best distortion performance of any of the **NSL-32** series. This is an important consideration when being used as a linear attenuator, since it will not be being driven hard **ON** or **OFF** as in a switching circuit, where the coupler distortion characteristics are less critical. Wherever possible it is best to drive the coupler LED from a constant current source, to minimize the effects of variations in LED forward voltage from device to device and with temperature: a simple circuit that gives 1 mA per Volt input is shown in **Figure 5**.

The measurements of the various circuits were taken with an input level of +10 dBu at 1 KHz, and the distortion (THD+N) measured with a 30 KHz bandwidth. Although some of the distortion figures may seem less than ideal, 3 factors should be borne in mind:

- 1) These measurements were taken at fairly high levels, typically corresponding to -6 dBFS on professional equipment, and will decrease rapidly with input level typically being 3 to 4 times less at 0 dBu, and virtually unmeasurable at -20 dBu.
- 2) The distortion products produced by an Audiohm coupler are all low order, second and third harmonics, which are much less objectionable than high order harmonics produced by crossover artifacts.
- 3) In the series/shunt and hybrid series/shunt attenuator configurations the worst distortion occurs at high attenuations, where the output signal level is so low that the distortion is unlikely to be very noticeable.

Figure 1

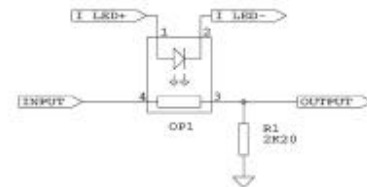

Figure 2

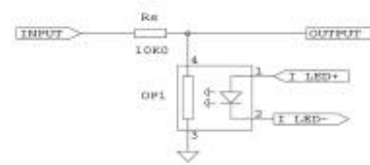

Figure 3

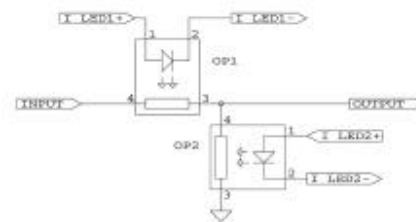

Figure 4

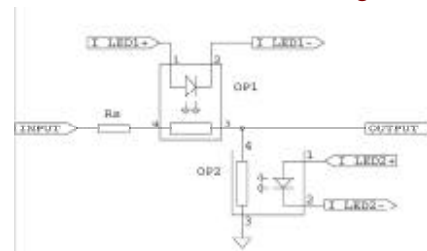
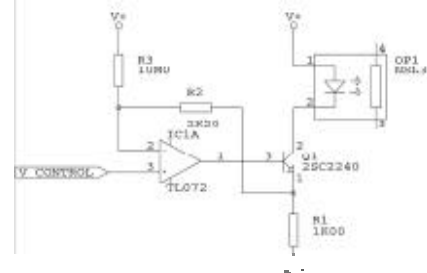

Figure 5



Series attenuator

Figure 6 shows the attenuation and distortion vs. control voltage of the circuit in **Figure 1**, driven by the constant current source. Please note that the horizontal scale is in mA, for example 300 m =300 microamps. Input signal was 1 KHz, +10 dBu. The high dark resistance of the **NSL-32SR3** gives quite good attenuation (typically about 80 dB at 1 KHz). However the circuit's usefulness is limited by the highly non-linear relationship between LED current and attenuation, and high distortion levels at any attenuation level below -10 dB. This is because the voltage across the non-linear cell resistance increases as the coupler turns off. Time constants are approx 0.5 and 12 msec for increasing and decreasing gain respectively. At frequencies above a few hundred Hz, the maximum attenuation is determined mostly by the cell parasitic capacitance and hence decreases with frequency.

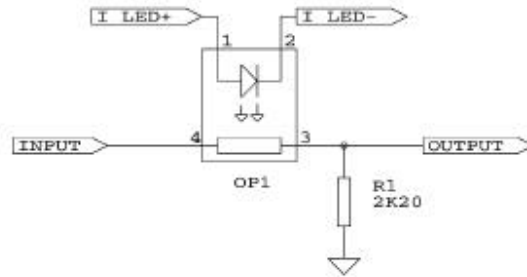
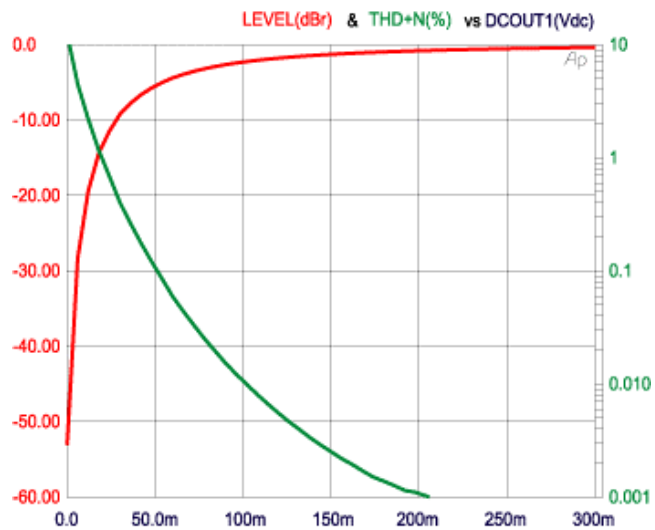

Figure 6



Shunt attenuator

In this configuration (**Figure 2**) a coupler with low R_{ON} , for example the **NSL-32SR2**, provides the best **OFF** attenuation for a given LED current. With $R_s = 47\text{ K}\Omega$ and $I_{LED} = 10\text{ mA}$, 60 dB can be readily obtained. However, the time constant for increasing the gain will be something like 300 msec, which will cause a noticeable lag in response. To get an equivalent attenuation from the faster SR3 device requires an R_s of 100 K Ω , which may give noise and interference pickup problems. The output needs to feed into a high impedance buffer amplifier to minimize insertion loss, a FET input device is ideal.

The attenuation and distortion response of this circuit is shown in **Figure 7**, note the peak in distortion at 2 to 3 dB attenuation. At very low currents the cell resistance is so high that the non-linear resistance of the cell has little effect, even though it has the full signal voltage across it. At high currents the cell resistance is low with most of the signal dropped across R_s , and since the cell non-linearity is proportional to the cell voltage, distortion is low. It is at currents where the cell resistance is a little less than R_s but still has a large proportion of the signal across it that the worst distortion occurs. Also note that the rising THD+N below 25 dB attenuation is *not* due to distortion, but inherent circuit and measurement system noise. If measured with a FFT analyzer, the distortion continues to fall with attenuation.

Alternatively a two-stage attenuator as shown in **Figure 8** can be used. This has the advantage of not taking any more drive current than a single stage, as the LEDs are in series, whilst almost doubling the attenuation range for a given R_s . **Figure 9** shows the response. Although the control law is not linear, it is gentle enough to give a smooth response if the control voltage is derived from a potentiometer with a reverse logarithmic law.

Figure 2

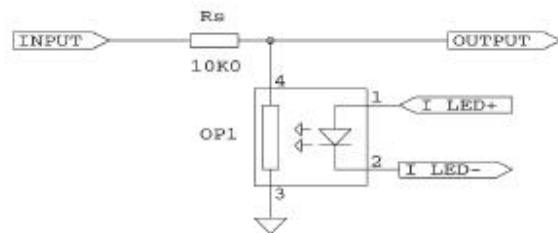

Figure 7

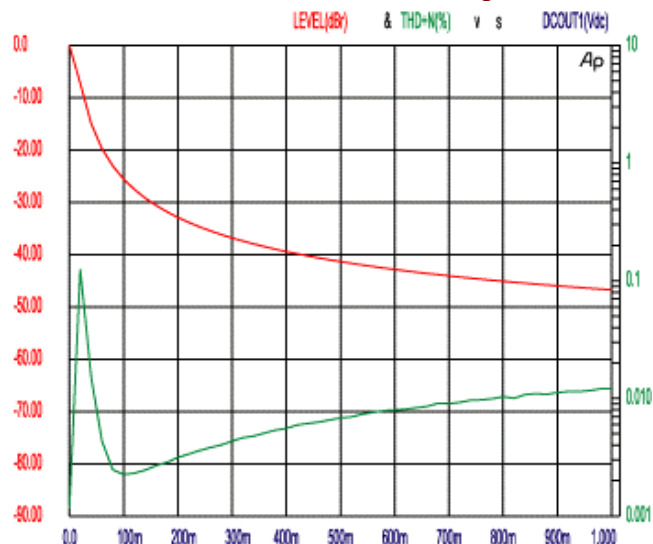
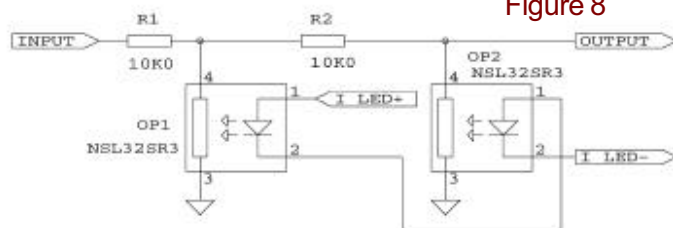
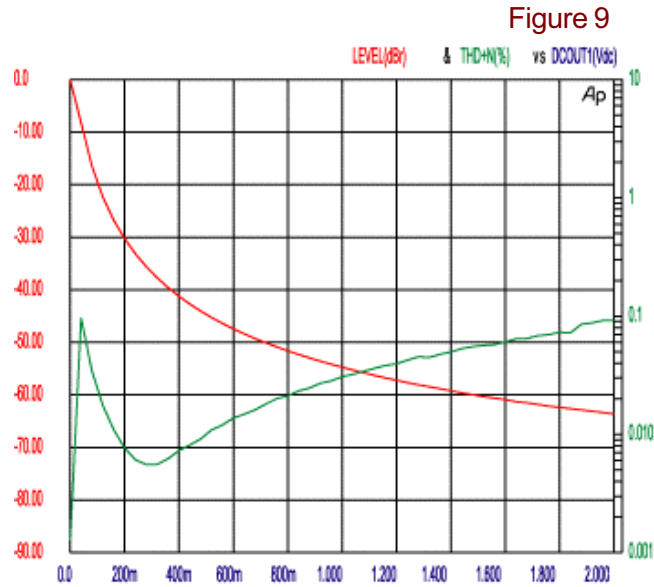

Figure 8



Audio level control with resistive optocouplers.



Series/shunt attenuator

This configuration (**Figure 3**) achieves better OFF attenuation and symmetrical time constants, at the expense of an additional coupler. The circuit could be driven by complementary current sources, but the simple arrangement shown in **Figure 10** saves complexity and current consumption, and also gives a reasonable dB/linear control law over a good proportion of the range. With the values shown, the circuit imitates a 5 KΩ potentiometer, although there is some overall variation in total resistance with attenuation, so it should be fed from a low impedance source. C1 sets the up and down time constants at about 20 msec, which achieves a fast but smooth audible response. The attenuation and distortion curves are

Figure 3

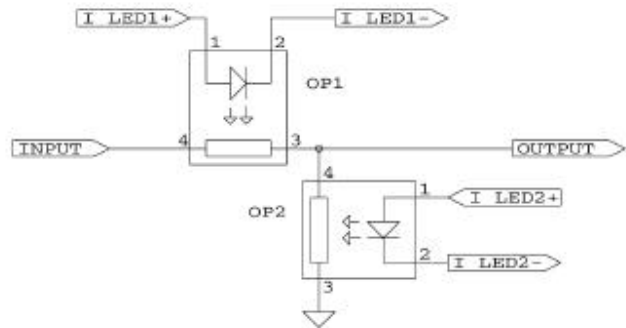
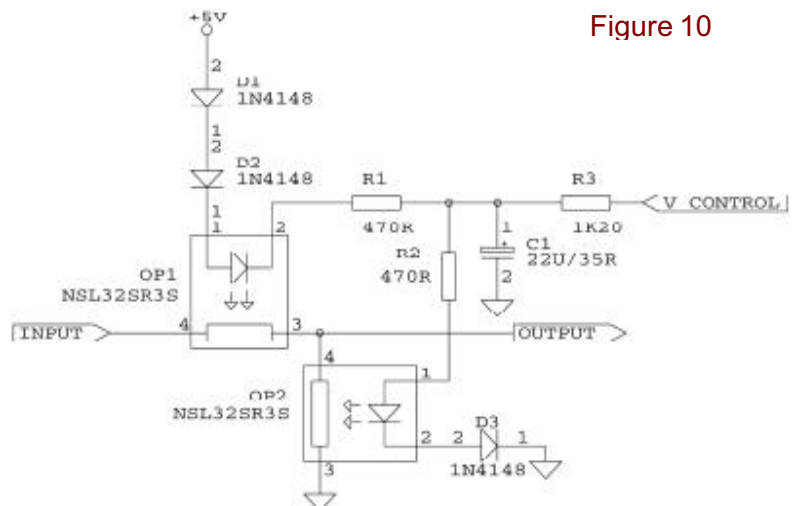

Figure 10



shown in **Figure 11**. Note the distortion null at 6 dB attenuation where both couplers have the same resistance.

The hybrid series/shunt arrangement shown in **Figure 12** gives an improvement in distortion performance, shown in **Figure 13**, by using resistor R3 to drop a proportion of the signal at low to medium levels of attenuation. The "bent" attenuation law is useful, giving greater resolution in the normal working area of the control, and a sharper response towards cut-off. To further improve on this distortion performance there are two possibilities:

- a) Use a coupler with a higher voltage rating, for example the **NSL-37V51**.
- b) Use two couplers in series to reduce the voltage across each cell.

The temperature dependence of the coupler LED and diode forward voltage drops makes the attenuation of these circuits somewhat sensitive to variations in ambient. Running the circuit from a 5 V supply that tracks the variation can compensate these dependencies, a suitable circuit is shown in **Figure 14**. The LED should be an AlGaAs type. The control voltage will also need to be referenced to this.

Figure 11

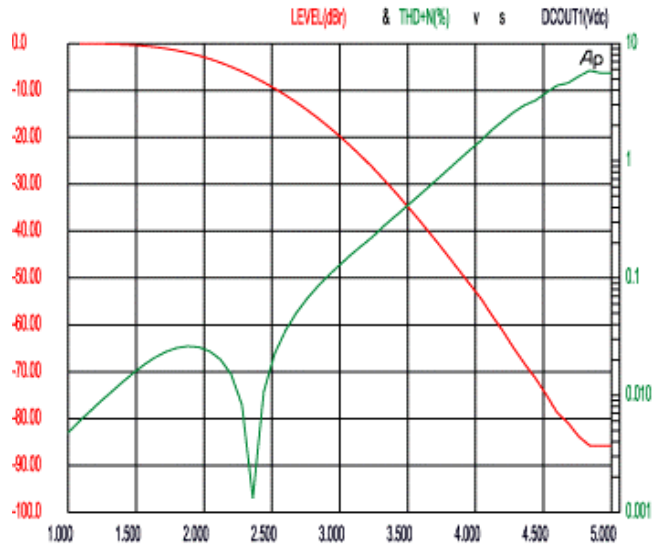

Figure 12

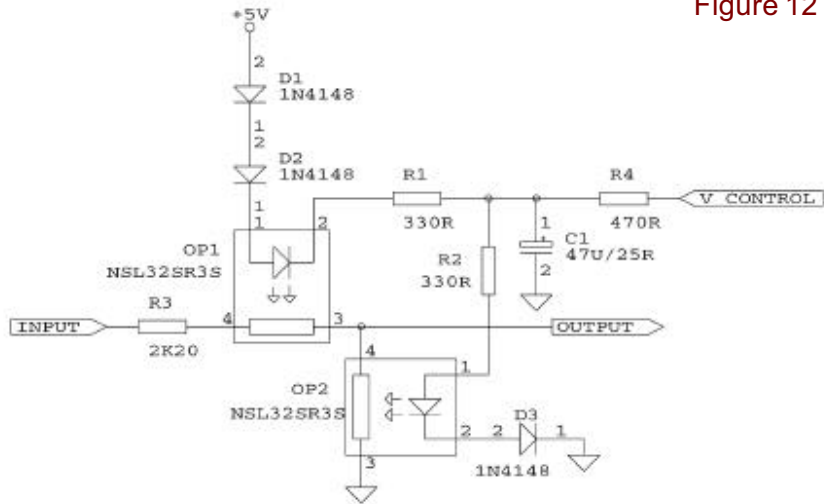

Figure 13

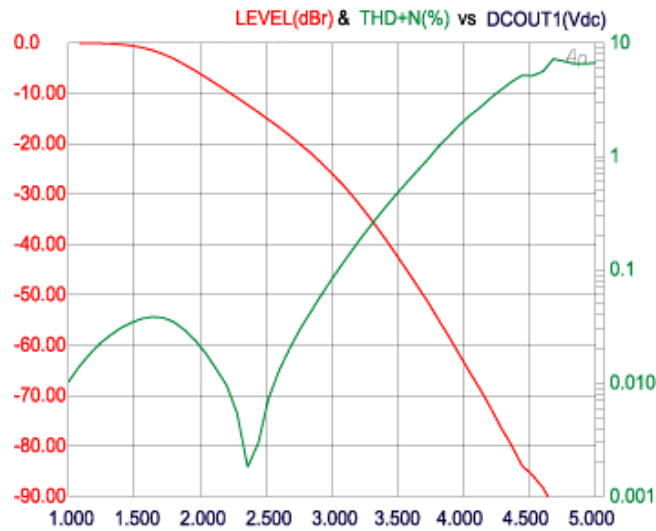
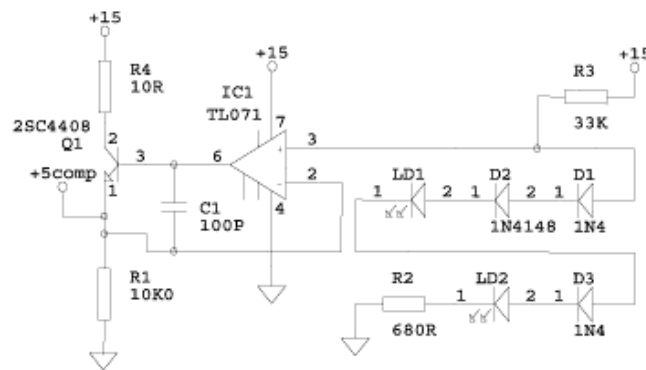

Figure 14



Circuit with defined attenuation law.

All the above circuits have a control law, which is determined by the inherent characteristics of the couplers and supporting devices. Although consequently non-linear, it is useable for many simple applications. If a truly linear response is desired the circuit of **Figure 15** can be used. A shunt attenuator is placed in the feedback loop of IC1, which sets the current through the coupler OP1 such that the feedback voltage on IC1 pin 3 is equal to the control voltage applied to R1. Matched coupler OP2 has the same current flowing through its LED as OP1, forming a shunt attenuator linearly controlled by V_CONTROL. OP1 should feed a high load impedance for best linearity and insertion loss. C1 provides frequency compensation around the loop for stability. The output attenuator is of course fully floating and can be run hundreds of volts away from the control circuit. This feedback control could equally be applied to a series/shunt circuit giving a floating linear potentiometer output.

Figure 15

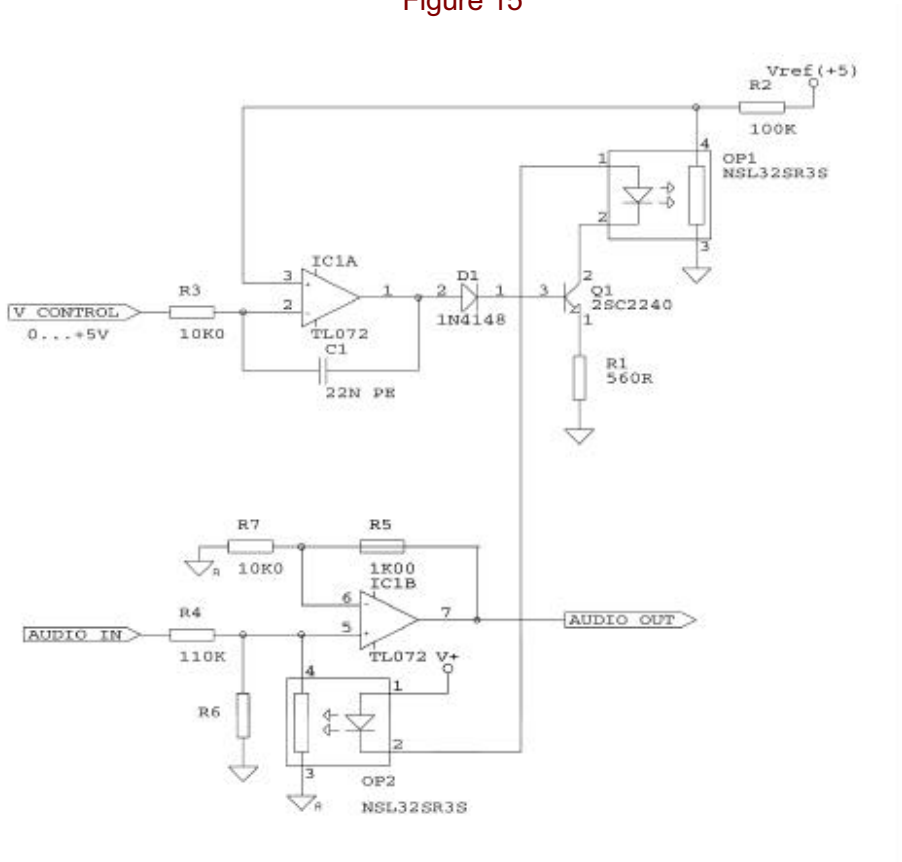

Crossfader

Frequently in audio mixing it is desirable to fade between one source and another. A standard slider potentiometer can be used for this purpose. Unless the highest quality conductive plastic elements are used, the track rapidly degrades with use, giving rise to contact noise as the wiper is moved. The circuit in **Figure 16** helps reduce this by using the potentiometer (designed for DC use) to generate control voltages. These in turn control two sets of Audiohm couplers that determine the relative gains of the audio channels. Capacitor C1 smoothes the wiper voltage of the potentiometer, which is buffered by IC1a to reduce wiper current, thereby reducing contact noise. The complementary control voltages are slightly "bent" by the networks around LD1 and LD2 to give the smoothest fade law, and then fed to IC2a and IC2b which have OP1 and OP2 in their feedback loops, in the same way as the circuit of **Figure15**. As shown with matched **NSL-32SR3S** couplers the maximum attenuation is typically 60 dB, and the insertion loss less than 0.2 dB. For a greater attenuation range two-stage attenuators could be used, or alternatively the A and B signals from the emitters of Q1 and Q2 could be used to fire muting switches when the potentiometer is at either extreme.

Figure 16

